

ENGLISH **WOLFVISION**[®]

Professional Visualizer Series **VZ-P18** and **VZ-P38**



A Classic in the Design of the new Decade

For more than 2 decades WolfVision's Professional Visualizers have been regarded as the ultimate high-end units on the market. The first Visualizer VZ-10, launched at the Photokina in 1988, already contained WolfVision's patented recording system through two mirrors and synchronized light/image lenses. Up to the present day this system still remains unbeatable in terms of depth of focus, shadow free illumination and intuitive positioning of objects.

The Professional Visualizer series has been constantly improved over the last 20 years. A total of 18 different models have been released.

Now in the 22nd year of its success story, the latest models VZ-P18 and VZ-P38 have a completely redesigned housing adapted to the "look and feel" of the new decade.

The unit's main body, which contains the entire technology, has been designed so that it can easily be recessed into a table in order to create a very flat working surface.



Touch Screen Remote Control with Live Image

The VZ-P18 and VZ-P38 are the first Visualizers on the market with a touch screen remote control. Just like with the Visualizers themselves, the remote control only contains high end components. Features, which until recently were technically impossible, are now reality, such as the live image preview feature.

Transmission by radio offers the advantage of a high operating distance of more than 10 meters (33 feet) and good reception reliability. The menu settings are self-explanatory and offer various user levels. A digital laser pointer, by means of a motion sensor, is clearly visible on any kind of screen, and size and colour can be adjusted accordingly. The remote control's storage space on the unit is also its docking station, and once docked the remote control is recharged. If a Visualizer firmware update has been performed, the docking station will automatically update the remote control's firmware.





Easy Positioning of Objects with Synchronized Lightfield



A very common mistake when working with a Visualizer is that speakers tend to place a document or object on the working surface without realising that what they are talking about is not actually in the picture. This happens so often because they are concentrating on the presentation and not the audio visual equipment at hand.

This is why a very simple and intuitive aid for the positioning of objects is a basic requirement for a professional presentation. The most sophisticated of all is WolfVision's patented Synchronized Lightfield.

The illuminated part on the working surface is always identical to the pick-up area of the camera. When zooming in and out the size of the lightfield changes accordingly.

All a presenter needs to do is to place the object in the illuminated part of the Visualizer's working surface. This is so self-explanatory that it is almost impossible to misplace a document or object on the working surface.



Check out the elegant housing with the 360° (3D) viewer at: www.wolfvision.com/360

Motorized Arm and Top Mirror (for Scrolling)



Even switching the VZ-P18 and VZ-P38 on and off is an experience. With a simple press of the power key the arm raises automatically, the LCD monitor on the top mirror head comes out and the lightfield appears on the working surface.

In addition to the arm and the LCD monitor, the top mirror is also motorized. This allows for scrolling through text in a document by just pressing the up/down keys on the remote control from anywhere in the room.

Recording behind the unit is also possible in order to pick up extremely large objects or to show objects from the side.

Outstanding Mechanical Stability and Long Lifetime

Outstanding mechanical stability has always been a basic requirement for all WolfVision products. Our Visualizers are solid and built to last a very long lifetime.

Just "touch" the unit and "feel" the difference between a WolfVision Visualizer and any other unit on the market! The solid material speaks for itself.



Pick-up area in front of the unit



Pick-up area on the working surface



Pick-up area on the working surface

Built-in LCD preview monitor

In addition to the remote control, a second LCD monitor can be found on the top mirror of the VZ-P18 and VZ-P38. This monitor is mainly designed as a preview monitor for live image display. However, in case the remote control is unavailable, it can also be used as a touch screen monitor for controlling purposes. For ease of use, the operational concept and functionality of this monitor is identical to the touch screen monitor of the remote control.

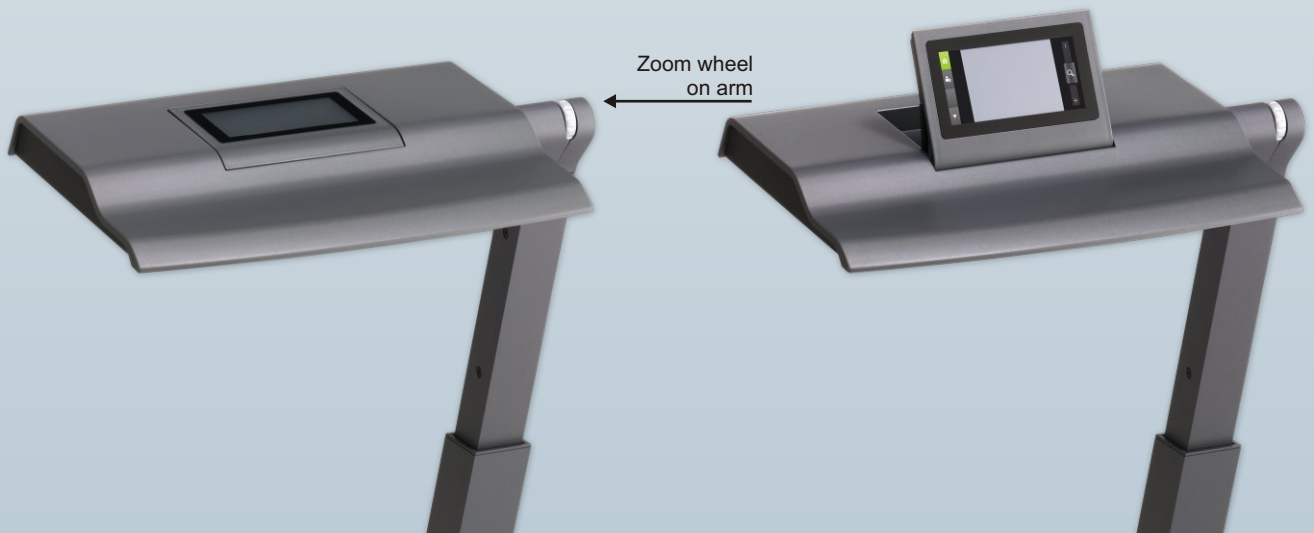

Zoom wheel on arm

Extremely High Depth of Focus (Depth of Field)

high depth of focus:



low depth of focus:



The Visualizers are equipped with professional telezoom lenses with a very high depth of focus. This is very important for working with larger 3-dimensional objects. Even at high magnification, they are always sharp from top to bottom.

The Visualizers are equipped with a One-Push-Autofocus. However, due to the great depth of focus it is rarely necessary to adjust the focus.

Shadow Free Illumination

no shadows:



shadows:



As the camera and the light projector are situated side by side within the Visualizer and follow the same path, shadows are almost completely eliminated.

During a presentation, it is often necessary to write something on a document on the working surface or to point to a certain detail with a finger or a pencil. The Visualizers are perfectly suited for this, as there are practically no shadows covering up the important details.

Illumination of Hollow Objects / No Light Adjustments

illuminated on inside:



not illuminated on inside:



Due to the special light system of the Professional Visualizers, every part of the recorded picture is always perfectly illuminated.

Hollow objects or complex 3-D objects are always completely illuminated - even on the inside.

As a result, there is never a need to adjust the light.

Firmware Updates / New Mainboard



WolfVision's Firmware Updates allow new features and technical improvements to be added at no cost!

Downloading firmware updates from the internet and uploading them onto a Visualizer can be done in just a few minutes. Serial (RS232), USB or LAN connections can be used for the update.

WolfVision's engineers are constantly working on new features and improvements to keep your units up to date with the technology of tomorrow!



The VZ-P18 and VZ-P38 have a new mainboard with even more computing power and additional resources (for more features and enhancements to be added at a later date via Firmware Updates).

Perfect Picture Quality through High End Components



Image lens



Light lens

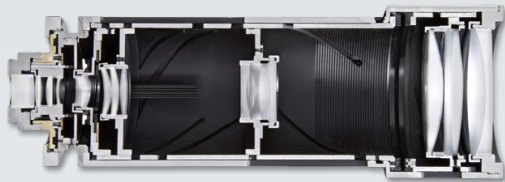

Inside of an image lens

The physical basics of Visualizers and video cameras are identical. A large **high precision lens**, manufactured with high end components, creates a better image than a small, lower priced lens.

A second high end telezoom lens and an energy efficient high brightness LED lamp form the Visualizers **light projector**. Perfect light is a basic requirement for perfect picture quality.

The next important component is the **camera** itself. The image quality of the VZ-P18's 1-CCD camera is remarkable, only to be outmatched by the 3-CCD camera of the VZ-P38. The advantages of the 3-CCD camera are even more lifelike colours and higher resolution with very detailed coloured objects.

The **electronic hardware** has a very large influence on the picture quality. Once again only high end components deliver the required computing power, stability and reliability. And last but not least comes the **software / firmware** of the Visualizer which brings out the full potential the electronic hardware provides.

The new electronic software and hardware already required more than 10 man-years of research and development, plus the combined experience of more than 20 years with the previous units.

The Visualizers VZ-P18 and VZ-P38 are a product of ultimate perfection.

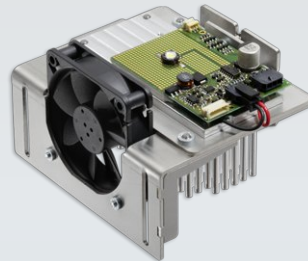

LED light system

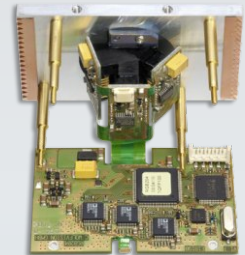

3-CCD camera



- 1 light projector
- 2 camera
- 3 light path
- 4 image path
- 5 base mirror
- 6 top mirror
- 7 pickup area

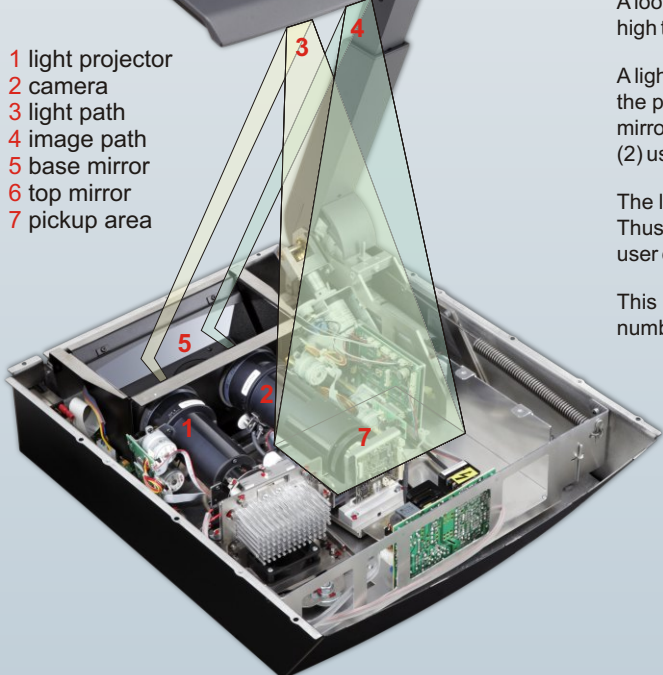

Technical Description of a Unique System

A look on the inside of the VZ-P18 and VZ-P38 reveals the large amount of high tech:

A light projector (1) inside the unit projects a light field (7) the same size as the pick-up area of the built-in camera via the base mirror (5) and the top mirror (6) onto the working surface. The image is recorded by the camera (2) using the same path.

The lenses of the light projector (1) and the camera (2) are synchronized. Thus the size of the light field on the working surface changes when the user changes the zoom range of the camera.

This patented WolfVision scanning and illuminating system offers a number of unique advantages as described in this brochure.

USB Device and USB Host Port

The **USB Device** port can be used for direct connections between the Visualizer and a computer. This way, a Visualizer can be used as a scanner for 3-dimensional objects. Images in JPG, TIF or BMP format can be taken in a fraction of a second - much faster than with a desktop scanner.

WolfVision's USB Software (Connectivity Software) works under Windows 2000, XP, Vista and 7 (32 and 64-bit) as well as Apple Macintosh. It is fully TWAIN/WIA compatible. This is important when using Visualizers in connection with graphic programs such as Photoshop, or for connecting them to Interactive Whiteboards (Smart Boards).

The fast USB 2.0 port can also output live motion. WolfVision's Connectivity Software can store AVI files and includes a video capture driver. You can view and save the live image from the Visualizer on your computer in almost every modern video editing software.



A new feature of the VZ-P18 and VZ-P38 is the **USB Host** port.

It can be used for connecting USB sticks and other "passive" USB devices. USB sticks can be used as an extension of the image memory and for uploading and downloading of images.

Upcoming Firmware Updates will increase the functionality of the USB Host port even more.



Internal and External Image Memory



Split image of memory

The user has the opportunity to store 9 images in the internal memory of the unit and recall them by just pressing one of the numerical keys on the infrared remote control. By pressing the "View All" key, a split image with all 9 pictures of the memory can be displayed, enabling easy selection.

When a USB stick is connected to the unit, the image memory can be extended to an almost unlimited number of images (upper limit is the size of the USB stick).

Computer Input



Instead of connecting a computer directly to a monitor or projector, the monitor output of the computer can be connected to the external input of the Visualizer. This has the advantage that a user can use the Ext/Int key of the Visualizer to switch between the Visualizer image and the computer image.

There is no need to use a second remote control of a projector or monitor to switch between the image sources.

Digital Scaler

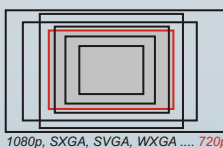

The Visualizer has a built-in digital image scaler which can process the signal from the external input and output it in the same mode as the Visualizer image. (For example: If the Visualizer is set to output an SXGA image to the projector and the computer outputs an XGA signal, the scaler of the Visualizer converts the XGA image of the computer to SXGA. As a result the projector does not readjust the input mode when switching between the Visualizer and computer image).

It can also digitize the analog RGB signal from the computer and output it on the digital DVI output. In addition, images on a connected USB-stick are automatically scaled to the current output mode of the Visualizer.

Integrated Seamless Switch

Computer image



Visualizer image

The Visualizer comes with an integrated Seamless Switch.

This allows fade-over/dissolve effects when switching between the Visualizer image, the image from the external input, the internal image memory of the Visualizer and pictures on a USB stick.

This feature makes switching from one media to the other appear very smooth and professional. Direct fade-over between two images and fading over black is possible.

Live to Freeze Comparison (on two Displays)

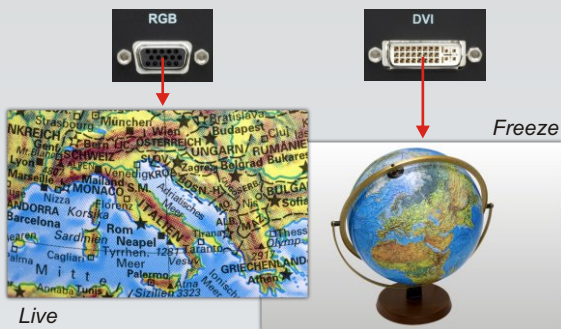

The DVI and RGB outputs of the Visualizer can be set to output different signals. One of them can always output the live image of the Visualizer's camera, while the other one can be set to output a "freeze" image.

This can be used for a "Live Picture to Freeze Picture Comparison" on two monitors or screens with just one Visualizer.

While one monitor or screen displays a "freeze" image that can be used for comparison, another monitor or screen can be used for presenting the live image from the Visualizer.

Live to Freeze Comparison (Picture in Picture)



A „Live Picture to Freeze Picture Comparison“ is also possible on a single monitor or projector.

In this case the Visualizer uses a „Picture in Picture“ function and shows the freeze image as a small picture in the lower left corner of the live image.

This function can be activated with a Preset key.

Professional Power Point Integration (Live image for Power Point)

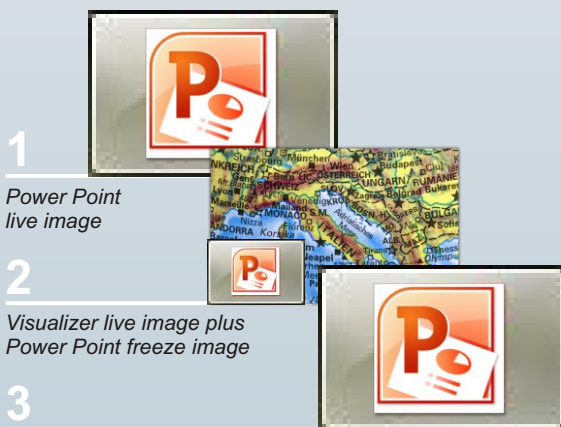

1
Power Point
live image

2
Visualizer live image plus
Power Point freeze image

3
Power Point live image

Presentations with Power Point are very common these days, but they can easily distress a speaker if the need to show something unexpected comes up during a presentation. This is where the Visualizer comes in as the perfect solution, because everything can be quickly placed on the working surface and displayed to the audience - spontaneously and without any preparation.

The mixture of both medias - Power Point and Visualizer - combines the best of both worlds and makes a presentation a lot more flexible. The VZ-P18 and VZ-P38 can be integrated into a Power Point presentation as professional as never before.

Connect the computer with the Power Point presentation to the external input of the Visualizer and switch between the Power Point and Visualizer image with the remote control of the Visualizer. The integrated Seamless Switch allows for professional fade-over effects between Visualizer and Power Point images.

The „Live to Freeze“ comparison feature is also perfectly suited for Power Point integration. By using the Preset key the Power Point image is frozen and minimized as a little image in the lower left corner of the picture, while the live image of the Visualizer is displayed in the main part of the picture. Using the Preset key again puts the Power Point image back to full screen mode.

LAN Port / Additional Network Features



The LAN port is a key feature of all high-end Visualizers from WolfVision. It makes the Visualizer a part of the internal computer network and it can be used for communication over the Internet, if it is assigned an official (WAN) IP address.

Administrators of a larger number of Visualizers can use the LAN port to control, support and update all of their units from their local desktop PC.

The list of applications for the Visualizers LAN port is constantly increasing. It can be used for controlling, capturing still images, viewing live video streams, firmware updates, adjustments, menu settings and maintenance purposes.



Authentication
for Built-in
Webserver



Streaming
in Multicast and
Singlecast (Unicast)

New LAN features of the VZ-P18 and VZ-P38:

Authentication:

In order to prevent unauthorized users from logging into the Visualizer over the network, it is now possible to set administrator and user passwords. The transmission of the passwords over LAN is encrypted with MD5.

Multicast/Singlecast Streaming:

The VZ-P18 and VZ-P38 offer streaming of live images from a Visualizer in Singlecast (Unicast) and Multicast mode.

Perfect for Video Conferencing



WolfVision's camera electronics produce a very strong and stable picture, which is very important when a Visualizer is used as a document camera for videoconferencing systems. The even lighting, smooth auto iris and perfect focus are very important features, enabling video conferencing systems to digitize and transfer the picture from a WolfVision Visualizer much faster than pictures from other document cameras. Furthermore there is no blinding stray light from a WolfVision Visualizer, which could disturb the auto iris of the room camera.

Of course these features are equally important for live image presentations with a data projector and for other Visualizer applications. The Visualizer also supplies the proper signal for modern widescreen videoconferencing systems.

Anti-theft Devices



The Visualizer has two anti-theft devices.

On the bottom of the working plate is a thread for attaching the unit to a table with the supplied table lock bolt. T-Lock (Kensington® Lock) devices can also be used. The connection can be found on the bottom of the arm.

The touch screen remote control of the unit can be firmly attached to the charging unit with a screw.

External Controlling

The Visualizer offers 4 different possibilities to control the unit from external devices, such as a remote control system for the whole room, a video conferencing system or a computer: Serial RS232, USB, LAN and radio remote control.



Enhanced RS232/LAN/USB-Protocol

The Enhanced Protocol of the Visualizer supports the same professional commands over the RS232, LAN and USB port. Thus the units support all of today's and tomorrow's external controlling devices.



Connectors and Dimensions

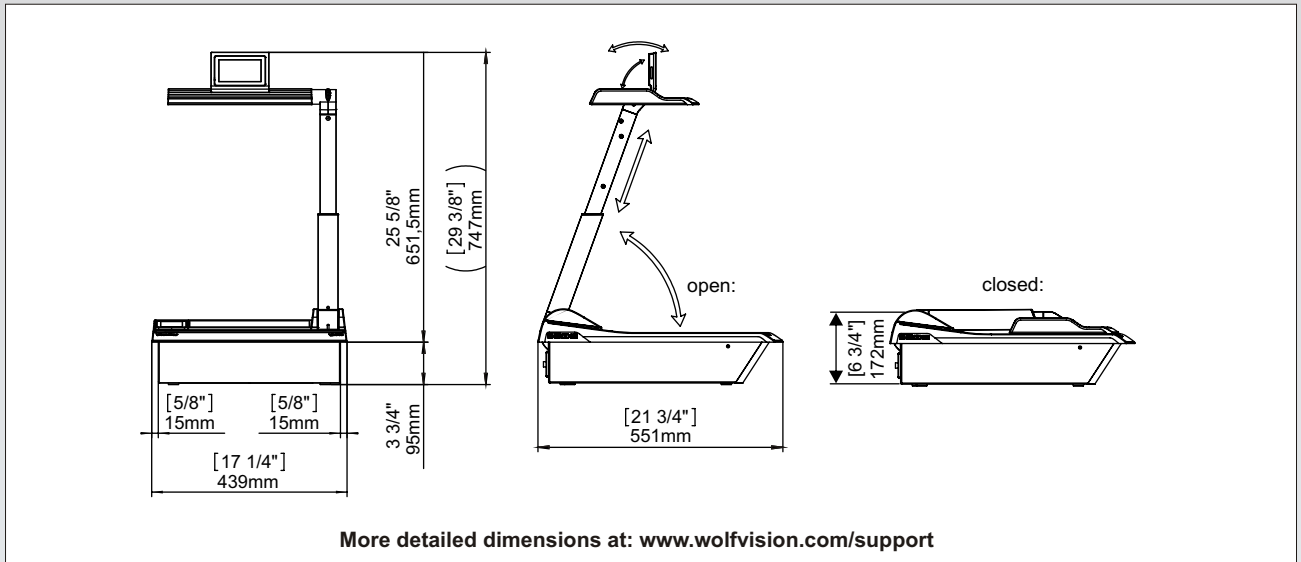
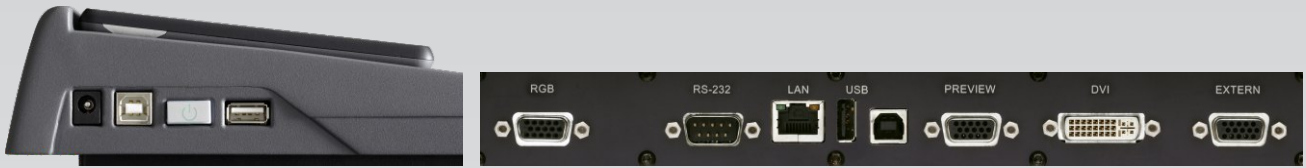

Technical Data

	VZ-P18	VZ-P38
Camera	1-CCD 1/3" Progressive Scan	3-CCD 1/3" Progressive Scan
Pictures per second	30 Frames (in all resolutions)	
Effective Pixel (=pixels actually used for image information)	1280 x 960 (=1.228.800)	3 x 1280 x 960 (=3.686.400)
Total pixels of CCD(s)	1.320.000	3.960.000
Pixels processed per second (=effective pixels x frames per second)	36.864.000	110.592.000
Color reproduction / precision	very good colors (sRGB color precision)	100% lifelike colors (sRGB color precision)
Native signal output	SXGA- (1280x960), WXGA (1280x800) and 720p HD (1280x720)	
Converted output signals (4:3 and 5:4)	UXGA (1600x1200), SXGA+ (1400x1050), SXGA (1280x1024), XGA (1024x768), SVGA (800x600)	
Converted Widescreen output signals (16:9 and 16:10)	WUXGA (1920x1200), 1080p HD (1920x1080), WSXGA+ (1680x1050), WXGA+ (1440x900), WXGA (1360x768)	
Resolution (measured)	820 lines	1200 lines
Resolution in Image Turn mode	1050 lines	1550 lines
Image Rotation	90, 180 and 270 degrees	
Iris & white balance adjustment	automatic and manual	
Autofocus / Speed	one-push-autofocus (focusing is rarely necessary due to high depth of focus)	
Manual focus	yes	
Shutter	auto, manual, flickerless	
Easy positioning of objects with "Synchronized Lightfield"	yes (with 4:3 / 16:10 switching)	
Built-in LCD preview monitor	2 pcs.: on camera head and remote control, size: 96 x 49mm / 3.8" x 1.9"	
Live to Freeze comparison (on two monitors or screens with just one Visualizer)	yes (RGB, DVI and Preview outputs can output different signals. One can output a live image and another one a "freeze" image)	
Live to Freeze comparison (Picture in Picture)	yes (still image is a small picture, integrated into the large live image)	
Power Point integration (with connected PC)	Cross-fading between Visualizer and Power Point Images and Picture in Picture	
Power Point substitution (without connected PC)	Power Point images exported as JPG can be displayed without PC, including cross-fading	
On screen menu and on screen help	yes	
Firmware Updates via	USB, RS232, LAN, USB-Stick	
Zoom / Lens	two telezoom lenses, 64x zoom (16x optical + 4x digital), zoom wheel with multiple speed	
Max object height on working surface	300mm (11.8") in tele and wide position	
Max. pick-up area on working surface	length: 300mm (11.8"), width: 400mm (15.7")	
Max. pick-up area on working surface in Image Turn mode	length: 400mm (15.7"), width: 300mm (11.8")	
Min. pick-up area on working surface (in full resolution, with optical zoom)	25 x 18.5 mm (1.0" x 0.7")	
Min. pick-up area on working surface (with digital zoom)	6.3 x 4.6mm (0.25" x 0.18")	
Max. pick-up area outside of working surface	unlimited	
Depth of focus on small object (42 x 33 mm)	70mm (2.75")	
Depth of focus on large object (360 x 270 mm)	260mm (10.2")	
Tilt range of camera	105° (30° to speaker + 75° to audience)	
Shadow free illumination	yes	
Illumination of hollow objects	yes	
Blinding of audience or speaker	none	
Light source	Maintenance free high-brightness LED light system (high light output, low power consumption), lamp lifetime: 30,000 hours	
Connectivity Software (USB/LAN, for controlling, image and video capturing and firmware updates)	included (for 32- and 64-bit Windows and Macintosh, Twin/WIA compatible, with video capture driver)	
Reflection free area on working surface	whole working surface	
Recordings outside of the working surface	yes (to the back of the unit)	
Intelligent folding system	motorized arm	
Motorized arm	yes	
Motorized top mirror (for scrolling text with remote control)	yes	
User programmable presets	3 user-presets + 1 power-on preset + fixed presets through command list	
Special working surface for transparencies	yes	
Bottom light	optional external lightboxes (extremely large models like WolfVision's LB-38 can be used)	
External computer input / Input switch	yes (15-pin D-Sub/VGA plug)	
Built-in digital scaler for the computer input	yes (processes the signal from computer input for RGB- and DVI-output)	
Seamless switch with fading effects	yes	
Advanced keystone correction	yes	
Image memory	9 pictures in internal memory + unlimited number on USB-stick	
9 image split-screen ("View function")	yes	
Alternative Image display	text enhancer / negative image / negative-blue image / black and white image	
RGB output	2x 15-pin D-Sub/VGA-plug	
DVI output	DVI-I (digital and analog)	
HDMI output	when using a DVI-HDMI cable	
USB standard / port	Two USB 2.0 device ports and two USB 2.0 host ports	
Ethernet/LAN port, IP-addressable	yes, 10/100 Mbps	
Additional LAN-features: multicast and singlecast streaming, authentication	yes	
RS232 port	9-pin D-Sub	
Advanced controlling with professional protocol via RS232, LAN and USB	yes	
Weight	16 kg (34 lbs)	
Remote control	Touch screen radio remote control (range: min. 10m / 33 ft) with integrated preview monitor, battery charger on the Visualizer, firmware upgradable	
Anti-theft devices	T-Lock (Kensington® Lock), table lock bolt and screw on remote control	
Power	Internal power supply, multi range 100-240 V, 80W, power consumption: 49W	
Warranty	3 + 2 years	

All units made in the European Union (Austria).

Design and specifications subject to change!

Your WolfVision dealer:



More Information at:
www.wolfvision.com

Head Office:

WolfVision GmbH, Klaus/Austria
Tel ++43-523-52250 | Fax ++43-523-52249
wolfvision@wolfvision.com

WolfVision Germany
Tel 0800-9828-787 | Fax ++43-523-52249
wolfvision.deutschland@wolfvision.com

WolfVision UK Ltd, Manchester
Tel 0161-435-6081 | Fax 0161-435-6100
wolfvision.uk@wolfvision.com

WolfVision Inc, USA East, Duluth (Atlanta)
Tel (770)931-6802 | Tollfree 1-877-873WOLF
Fax (770)931-6906 | usa.east@wolfvision.com

WolfVision Inc, USA West, Burlingame (San Francisco)
Tel (650)648-0002 | Tollfree (800)356-WOLF
Fax (650)648-0009 | usa.west@wolfvision.com

Wolfvision Canada Inc, Ottawa
Tel 613-741-9898 | Fax 613-741-3747
wolfvision.canada@wolfvision.com

WolfVision Asia, Singapore
Tel ++65-6366-9288 | Fax ++65-6366-9280
info@wolfvisionasia.com

WolfVision Co Ltd, Japan, Tokyo
Tel ++81-3-33603231 | Fax ++81-3-33603236
wolfvision.japan@wolfvision.com